



# WARRANTY INFORMATION

We sincerely thank you for your purchase and wish you years of pleasure using it!

## Tele Vue Warranty Summary

Eyepieces, Barlows, Powermates, & Paracorr have a “Lifetime Limited” warranty, telescopes & accessories are warranted for 5 years. Electronic parts are warranted for 1 year. Warranty is against defects in material or workmanship. No other warranty is expressed or implied. No returns without prior authorization. Please keep your receipts in case you need warranty service.

Lifetime Limited Warranty details online: <http://bit.ly/TVOPTLIFE>

5-Year/1-Year Warranty details online: <http://bit.ly/TVOPTLIMITED>

Subscribe to our Blog for the latest Tele Vue news: <https://bit.ly/TeleVueBlog>

### Keep For Your Records

Dealer: \_\_\_\_\_ City/State/Country: \_\_\_\_\_

Date (day/month/year): \_\_\_\_ / \_\_\_\_ / \_\_\_\_ Item Code / Description \_\_\_\_\_

32 Elkay Dr., Chester, New York 10918 (845) 469-4551. [televue.com](http://televue.com)



@televueoptics

# DIAGONAL MIRROR CLEANING

This diagonal has a high efficiency mirror which requires special handling. Scratches happen when dust or other abrasive particles are on the mirror and are wiped across the surface during cleaning. Clean mirror ONLY when absolutely necessary.

- 1) Remove dust, dirt, grease, etc., from the mirror surface. Use rubber ear syringe (purchased at any drug store) to blow off loose contaminants.
- 2) Make a pad with lens cleaning tissue (such as Kimwipes®), moisten it with fresh isopropyl alcohol (90% or better) or Methanol to wash off grease. Gently wipe across mirror surface using only the weight of the pad. Do not rub, this will scratch the mirror. Do not touch the metal parts.
- 3) Slight residual stains or dust spots will have absolutely no visible effects in observing.

**CAUTION:** Do not clean mirror with water or water-based cleaners such as Windex® or any other commercial lens cleaners. This is not a lens. All contain too much water and will leave residue.

V1/16/2016



32 Elkay Drive, Chester, New York 10918 845.469.4551 [www.televue.com](http://www.televue.com)

# DIAGONAL MIRROR CLEANING

This diagonal has a high efficiency mirror which requires special handling. Scratches happen when dust or other abrasive particles are on the mirror and are wiped across the surface during cleaning. Clean mirror ONLY when absolutely necessary.

- 1) Remove dust, dirt, grease, etc., from the mirror surface. Use rubber ear syringe (purchased at any drug store) to blow off loose contaminants.
- 2) Make a pad with lens cleaning tissue (such as Kimwipes®), moisten it with fresh isopropyl alcohol (90% or better) or Methanol to wash off grease. Gently wipe across mirror surface using only the weight of the pad. Do not rub, this will scratch the mirror. Do not touch the metal parts.
- 3) Slight residual stains or dust spots will have absolutely no visible effects in observing.

**CAUTION:** Do not clean mirror with water or water-based cleaners such as Windex® or any other commercial lens cleaners. This is not a lens. All contain too much water and will leave residue.

V1/16/2016



32 Elkay Drive, Chester, New York 10918 845.469.4551 [www.televue.com](http://www.televue.com)



# WARRANTY INFORMATION

We sincerely thank you for your purchase and wish you years of pleasure using it!

## Tele Vue Warranty Summary

Eyepieces, Barlows, Powermates, & Paracorr have a “Lifetime Limited” warranty, telescopes & accessories are warranted for 5 years. Electronic parts are warranted for 1 year. Warranty is against defects in material or workmanship. No other warranty is expressed or implied. No returns without prior authorization. Please keep your receipts in case you need warranty service.

Lifetime Limited Warranty details online: <http://bit.ly/TVOPTLIFE>

5-Year/1-Year Warranty details online: <http://bit.ly/TVOPTLIMITED>

Subscribe to our Blog for the latest Tele Vue news: <https://bit.ly/TeleVueBlog>

### Keep For Your Records

Dealer: \_\_\_\_\_ City/State/Country: \_\_\_\_\_

Date (day/month/year): \_\_\_\_ / \_\_\_\_ / \_\_\_\_ Item Code / Description \_\_\_\_\_

32 Elkay Dr., Chester, New York 10918 (845) 469-4551. [televue.com](http://televue.com)



@televueoptics

**Introduction**

Thank you for purchasing the Mount Ring Set for your Tele Vue telescope. The Mount Ring serves three purposes: Firstly, it provides a secure mounting for your telescope to your Tele Vue mount, or to other mounts via adapters. Secondly, it provides a means for fore and aft balancing when you change eyepieces. Thirdly, the Ring Mount holds accessories, such the Starbeam finder or Piggy-Cam, via machined channels in the top half.

**Features**

The inside of the Rings are lined with a thin felt layer to prevent scratching the tube when adjusting balance and provide ample friction to hold your telescope in place. The Mount Ring bottoms have 1/4" studs and guide pin studs to mate with the mounting plate. The accessory channels are tapped with #10-32 threads to accept Starbeam and other Tele Vue accessories. The included mounting plate attaches to the Gibraltar5 Head (G5H-3016), and to Tele Vue's Vixen Mount Adapter (AVT-1011) for use with Vixen-style equatorial mounts. See diagram at bottom for features of the mounting plate.

**Mount Ring Installation and use**

The Mount Ring comes fully assembled. To install on the telescope you will need to separate the upper and lower halves.

- 1) Unscrew and remove the four bat handles. To loosen, start with the handle flipped to the left as you face it. Rotate the handle all the way to the right. Flip the handle back to the left and repeat until you are able to turn the screw with the handle oriented straight up. Tightening is simply the opposite procedure.
- 2) Place the scope in the lower half of the Mount Ring Set and then place the upper half of the Mount Ring Set on top of the scope.
- 3) Thread in the four bat handles just a couple of turns each. The Mount Ring will be very loose on the tube.
- 4) Progressively tighten the right, then left, side bat handles so the gap between the upper and lower halves remains relatively consistent from side to side and front to back. Continue to tighten the bat handles until the telescope tube is secure in the Mount Ring Set.

**Balancing**

- 1) When adjusting balance due to changing eyepieces, snug the mount's altitude tension screws, or hold the telescope tube since the telescope will become unbalanced when you remove the eyepiece.
- 2) Adjust balance by loosening the bat-handles on one side and sliding the telescope within the Rings. Loosen just enough so the telescope slides with force, but not so loose that it slips on its own. Re-tighten bat handles.

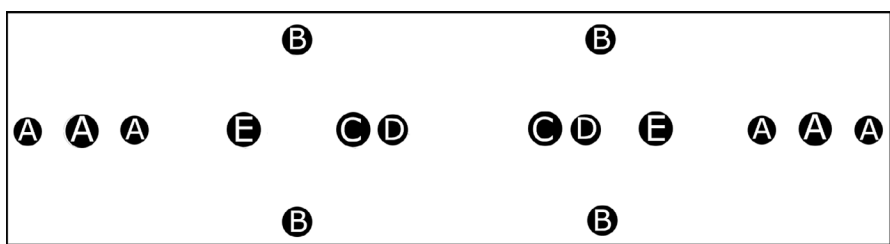
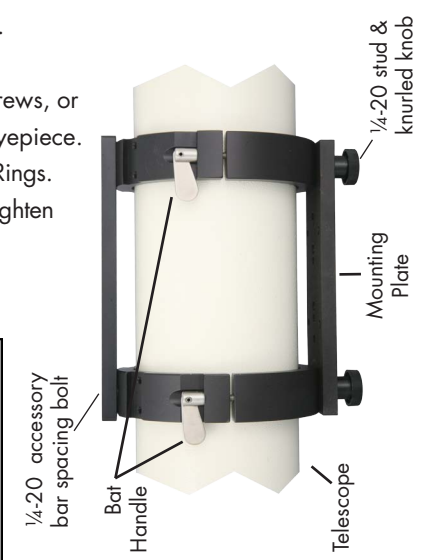

- A. Holes - These accept the mount ring studs (and guide pin studs on 5" rings) as shown in the scope cutaway diagram above.
- B. Holes - For use with the Tele Vue Gibraltar-5 Head. (Mounting instructions will come with the Gibraltar5)
- C. Holes - For use with other Tele Vue Ring Mounts. (By using longer than normal studs, other Tele Vue scopes can conveniently be attached to the Gibraltar5 Head without removal of the Mounting Plate.)
- D. Tapped Holes - For use with the Tele Vue's Vixen Mount Adapter plate (AVT-1011) adapters for attachment to Vixen mounts.
- E. Holes - For use with Vixen AM-AD-2576 (discontinued) accessory plate. The Vixen plate allows use of the NP127is and guide scope on Vixen mounts.

# **WARRANTY REGISTRATION FORM**

We sincerely thank you for your purchase and wish you years of pleasure using it!

## Tele Vue Warranty Summary

Eyepieces, Barlows, Powermates, & Paracorr have a "Lifetime Limited" warranty, telescopes & accessories are warranted for 5 years. Electronic parts are warranted for 1 year. Warranty is against defects in material or workmanship. No other warranty is expressed or implied. No returns without prior authorization.

Lifetime Limited Warranty details online: <http://bit.ly/TVOPTLIFE>

5-Year/1-Year Warranty details online: <http://bit.ly/TVOPTLIMITED>

Subscribe to our Blog for the latest Tele Vue news: <https://bit.ly/TeleVueBlog>

### Keep For Your Records

Dealer: \_\_\_\_\_ City/State/Country: \_\_\_\_\_

Date (day/month/yr): \_\_\_\_/\_\_\_\_/\_\_\_\_ **18.2 DeLite (EDE-18.2)**

**Tele Vue®**  
32 Elkay Drive  
Chester, NY 10918-3001  
U.S.A.

Please fill out, cut out, and mail form below within 2-weeks of product purchase. **Please include copy of sales receipt that has your name, the dealer name, and product name.**

Cut out mailing address at left, tape to envelope, insert form & sales receipt in envelope and apply sufficient postage to envelope.

### 18.2 DeLite (EDE-18.2)

Name Last \_\_\_\_\_ First \_\_\_\_\_

Street Address \_\_\_\_\_

City \_\_\_\_\_ State/Province \_\_\_\_\_

Postal Code \_\_\_\_\_ Country \_\_\_\_\_

Email\*: \_\_\_\_\_

Phone: \_\_\_\_\_

Astro Club: \_\_\_\_\_

How did you learn about this product?

- Dealer     Friend     Tele Vue Blog  
 CloudyNights.com     TeleVue.com  
 Social Media/Magazine/Other(s):

What made you decide to buy this and your comments after using the product?

### Purchase Information

Dealer: \_\_\_\_\_

City/State/Country: \_\_\_\_\_

Date (day/month/yr): \_\_\_\_/\_\_\_\_/\_\_\_\_

# DeLite™ EYEPIECE INSTRUCTIONS

Thank you for purchasing a Tele Vue DeLite eyepiece. Each DeLite model features 20mm of eye relief along with a 62° apparent field. Based on our Delos design experience, we were able to keep the size and weight down, while achieving the best sharpness, linearity (freedom from pincushion distortion) and ghost suppression over the entire field for any speed (f/#) telescope.

Your new DeLite eyepiece is designed for optimum viewing whether or not you wear eyeglasses. Our unique, new, adjustable, locking eyeguard housing allows for full eye relief for eyeglass wearers in the down position. Pulling the housing up will permit setting of the eyeguard height allowing for an ideal match between your eye and telescope pupils. With this much eye relief available, it is important to learn your own optimum position.

If you don't wear eyeglasses, start with the eyeguard housing pulled out all the way. To do so, grasp the upper rubber grip ring with one hand. With the other hand, grasp the lower grip and rotate to the left to loosen the assembly. Slide the eyeguard to the fully extended position. While looking through the eyepiece, slide the eyeguard down the barrel until you just see the full field with your peripheral vision. Note your eyeguard height using the green indicator lines engraved on the inner barrel. You may leave the eyeguard loose or lock its position by again grasping the grip rings in each hand and this time rotating the lower grip ring to the right. You will also find that this system minimizes extraneous outside light, giving you the highest contrast for those "faint fuzzies". The generous 20mm of eye relief also minimizes eye lens fogging due to eye moisture in cold weather.

This eyepiece is ideal for using the Tele Vue DIOPTRX™ to compensate for eyesight astigmatism. See reverse of page for details.

DeLite effective field stop diameters:

DeLite	EFS (mm)	DeLite	EFS (mm)	DeLite	EFS (mm)
18.2mm	19.1	11mm	11.7	5mm	5.3
15mm	16.0	9mm	9.6	4mm	4.3
13mm	13.8	7mm	7.5	3mm	3.2

To determine the true field in degrees for an eyepiece on any given telescope, simply divide the field stop diameter of the eyepiece by the focal length of the telescope (in mm) and multiply the result by 57.3 degrees (a radian).

## Proper Eyeguard Positioning

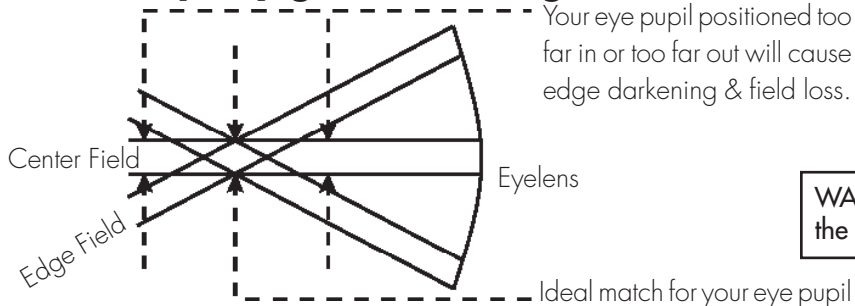

The eyeguard housing is made of two pieces. To loosen and move it, grasp a grip ring with each hand and twist the lower grip ring to the left. When the eyeguard is sufficiently loose you can slide it up the barrel. To tighten, again grasp both grip rings and twist the lower portion of the eyeguard housing to the right.



**WARNING:** To avoid getting dust and dirt into the eyepiece Do not unscrew the chrome barrel!

## This Eyepiece Accepts DIOPTRX™

Your telescope's focuser is used to compensate for your near- or far-sightedness; DIOPTRX™ compensates for your astigmatism. These units attach and lock onto the tops of over twenty long eye-relief Tele Vue eyepieces to achieve the sharpest full-field viewing possible. DIOPTRX™ models are available in ¼ to 3½ diopter and are rotatable for tuning to the best orientation. Simply choose the DIOPTRX™ model that matches your eyeglass prescription for astigmatism. All lenses are multi-coated glass in anodized aluminum housings with rubber eyeguards.



### Benefits of using Dioptx over eyeglasses

1. You're more likely to see a sharper, higher contrast image, because:
  - A. The Dioptx is always completely aligned to the eyepiece optics, eliminating aberrations from a decentered mismatch of eyeglass power and astigmatic axis.
  - B. Dioptx can be rotated to exactly compensate for the astigmatic axis angle in real time, since both head angle and age can vary your eyesight astigmatic angle.
  - C. Dioptx likely has better multi-coatings than eyeglasses, and certainly is better in transmission and reflection reduction than uncoated eyeglass.
  - D. Dioptx is more likely to be cleaner than eyeglasses, which may have scratches and smudges from constant use and wear and tear.
  - E. Dioptx allows seeing your normal maximum contrast that eyeglasses can diminish (remove your eyeglasses and see how contrast improves in normal vision).
2. You're more likely to see the full field in 100° Ethos eyepieces because your eyeglasses are more limiting in "effective eye-relief".

Enter [bit.ly/TVOPTDXM](http://bit.ly/TVOPTDXM) in browser URL bar for more info.

## SFA-0001

## This Eyepiece Accepts FONEMATE

If you need a convenient way to take still, video, or timelapse images through an eyepiece, use our FoneMate™ smartphone adapter. It securely clamps to compatible Tele Vue eyepieces. Smartphones as big as the Galaxy Note 4 can be fitted to the FoneMate™.

Enter [bit.ly/TVOPTFM](http://bit.ly/TVOPTFM) in browser URL bar for more info.



## VIP-2010

## VISUAL-IMAGING PARACORR TYPE-2

Newtonian/Dobsonian telescopes can benefit from using a Tele Vue Paracorr (Parabola Corrector) to eliminate coma in the image. Coma is the effect that makes off-center stars appear like little comets (it becomes more apparent as stars move closer to the edge of the field). While a Newtonian/Dobsonian telescope will benefit from the use of Paracorr, those faster than  $f/5.0$  will see the greatest results. Stars at the edge of the field will improve so dramatically, that when using top-notch Tele Vue eyepieces an object will be equally sharp anywhere in the field. It also prevents faint stars from disappearing at the edge of the eyepiece field. This is not only aesthetically pleasing, but it also greatly reduces the need to constantly nudge the scope to keep the object centered in the "sweet spot." Just insert Paracorr into your 2" focuser like a 2" Barlow (it has a 1.5% [1.15x] magnification factor) and add Tele Vue eyepieces to suit your needs. It's a recipe for perfection when combined with Tele Vue eyepieces.

The Paracorr Type-2 allows an  $f/3$  parabolic mirror to perform like an  $f/12$  without it. This permits development of a new generation of larger ladderless Dobs, with bigger, sharper fields than ever before. Indeed, it's already been successfully applied by Mike Lockwood to his 20"  $f/3$  and 14.5"  $f/2.55$ !

This model Paracorr is dual function: the tunable top permits positioning all Tele Vue eyepieces for optimum performance (see eyepiece position chart on the other side), and the optical assembly can be removed for use in an imaging system with DSLR or CCD cameras along with Tele Vue Imaging System accessories.



Enter [bit.ly/TVOPTPC](http://bit.ly/TVOPTPC) in browser URL bar for more info.

## This Eyepiece Accepts BANDMATE™ Filters

Adding Bandmate filters to your eyepiece make nebulae "pop-out" in the field. Bandmate does this by passing select wavelengths of light and blocking other to darken the sky and increase contrast. Several filters are available for 2" and 1 1/4" barrel eyepieces.

- Bandmate Nebustar is a unique narrowband filter design specifically for Tele Vue as a general-purpose nebula filter for scopes of any size. Unlike other ultra-high contrast (UHC) designs, Nebustar blocks red wavelengths normally passed by typical UHC filters. The design eliminates star bloat to produce sharper, more natural looking stars along with enhanced nebulosity.
- Bandmate OIII filter enhances planetary nebulae and supernovae remnants.
- Bandmate H $\beta$  brings out the hydrogen-beta emission lines found in hydrogen emitting nebulae.



Enter [bit.ly/TVOPBM2](http://bit.ly/TVOPBM2) in browser URL bar for more info.



# Choosing Your Eyepieces

by Al Nagler  
CEO, Tele Vue Optics, Inc

## MAGNIFICATION

Eyepieces determine your telescope's magnification.

$$\text{Magnification} = \text{telescope focal length} \div \text{eyepiece focal length}$$

## TRUE FIELD OF VIEW

Eyepieces also determine the true field you see in the sky. To calculate the true field of view that you will see (in degrees):

$$\text{True field of view} = (\text{eyepiece field stop diameter} \div \text{telescope focal length}) \times 57.3$$

## THE FIELD STOP AND APPARENT FIELD OF VIEW

The field stop is the metal ring inside the eyepiece barrel that limits the field size. It's projected by the eyepiece so that it appears as a circle out in space when you look through the eyepiece. The angular diameter of this circle is called the apparent field of view (AFOV) and is a fixed property for each eyepiece design. For example, Plössl and Nagler Zoom eyepieces have an AFOV of 50°, Panoptics have 68°, Delos have 72°, Naglers have 82°, Ethos have 100° and the Ethos-SX eyepiece has 110°.

## LOW-TO-MEDIUM POWER VIEWING

For low-power viewing of large objects, or to use your telescope as a low-power finder, use an eyepiece that delivers close to the maximum possible true field of view (note that for 1.25" eyepieces, the maximum field stop diameter is 27mm; for 2" eyepieces, it's 46mm). Then add eyepieces covering uniform increments in smaller field stops. For example, if your widest field eyepiece has a 40mm diameter field stop and you choose a decreasing increment diameter factor of 2 (which results in a 4x decrease in area size), you'll end up with eyepieces having field stop diameters of approximately 40mm, 20mm and 10mm. To further fill in with incremental steps, add eyepieces with approximate field stop diameters of 28mm and 14mm. Of course, avoid duplicating focal lengths. For example, if you use a 31mm Nagler (with a 42mm field stop diameter), you would not need a 32mm Plössl (with a 27mm field stop diameter).

In general, for each field stop size, choosing eyepieces with shorter focal lengths and larger apparent fields of view will allow you to see more detail and fainter stars. In addition, you'll have a smaller exit pupil to better match your eyesight.

## EYEGASSES AND EYE RELIEF

If you do not need eyeglasses to correct astigmatism, don't use them when observing. If you wear glasses to correct astigmatism, make sure they're multi-coated, and try to choose eyepieces that have at least 15mm to 20mm of eye relief, to minimize any field reduction (vignetting). However, you will find that with small exit pupils such as 1mm or less, you probably will not need eyeglasses, and can therefore use eyepieces with less eye relief. You can use DIOPTRX instead of eyeglasses for best performance, with Tele Vue eyepieces that accept this accessory.

## EXIT PUPIL

The exit pupil is the image of the objective that is formed by the eyepiece. It's where you place your eye to see the full field of view.

$$\text{Exit pupil} = \text{eyepiece focal length} \div \text{telescope } f\#\$$

For reflecting telescopes, it's best to avoid exit pupils larger than 7mm or smaller than 0.5mm. Refracting telescopes have no upper limits on exit pupil sizes.

## IMAGE AMPLIFIERS (Barlows and Powermates)

You can also choose a long focal length eyepiece with comfortable eye relief and use image amplifying lenses to increase power. Tele Vue makes Barlows and Powermates (an improvement to the Barlow-type design) in magnification factors of 2x, 2.5x, 3x, 4x and 5x.

## PARACORR Type-2 (Parabola Corrector)

If you have a Newtonian or Dobsonian reflector that's  $f/5.0$  or faster, you should seriously consider using the Paracorr to eliminate coma, so your full field eyepiece sharpness is not compromised. Paracorr also acts like a 1.15x image amplifier, so, for example, a 1000mm  $f/4.5$  scope becomes an 1150mm  $f/5.2$  scope. Adjust your eyepiece focal length choices accordingly. Paracorr Type-2 is for scopes as fast as  $f/3.0$ .

## HIGH-POWER VIEWING

Once you've selected an eyepiece set based on field stop sizes, calculate the magnifications produced with your scope. For planetary or double star observing, you'll want an eyepiece in at least the 150x range. For determining maximum power, a good rule of thumb is to use no more than 60x per inch of aperture for scopes with apertures up to 6". Higher magnifications may still be pleasing but will not likely reveal any additional detail. Realistically, the atmosphere will usually limit your planetary observing to a maximum magnification of about 300x, no matter how large your telescope aperture.

Basically, you'll be choosing low and medium power eyepieces by field stop increments to "frame" the subject, and high power eyepieces by magnification increments (based on your scope's aperture), to reach the optimum contrast and resolution for viewing planets and double stars.

Check out [www.televue.com](http://www.televue.com) for the following related articles: "Choosing Your Telescope's Magnification", "Eyepieces for Small Dobs" and "Determining When To Use Eyeglasses".

For more individual advice on specific applications, you can always call Tele Vue at 845-469-4551

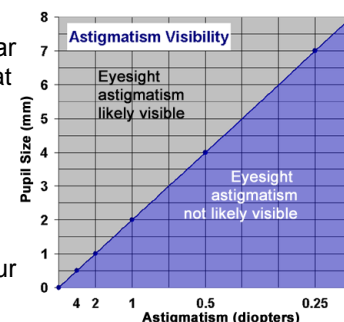

# TELE VUE EYEPIECE SPECIFICATIONS

Tele Vue recommends choosing low and medium power eyepieces in ratios of field stop diameters. For example, factors of 1.4 or 2.0. When choosing higher power eyepieces, use ratios of magnification.

Focal Length (mm)	Type	Product Code	Apparent Field (deg)	Field Stop Dia. (mm)	Eye Relief (mm)	Dioptx Ready	Pupil size in mm for various f/ratio telescopes				
							f/4.5	f/5.2	f/7	f/10	f/14
<b>2" Eyepieces for Wide True Fields</b>											
55	Plössl	EPL-55.0	50	46.0	38	Y	12.2	10.6	7.9	5.5	3.9
41	Panoptic	EPO-41.0	68	46.0	27	Y	9.1	7.9	5.9	4.1	2.9
31	Nagler 5	EN5-31.0	82	42.0	19	Y	6.9	6.0	4.4	3.1	2.2
35	Panoptic	EPO-35.0	68	38.7	24	Y	7.8	6.7	5.0	3.5	2.5
21	Ethos	ETH-21.0	100	36.2	15	Y	4.7	4.0	3.0	2.1	1.5
22	Nagler 4	EN4-22.0	82	31.1	19	Y	4.9	4.2	3.1	2.2	1.6
27	Panoptic	EPO-27.0	68	30.5	19	Y	6.0	5.2	3.9	2.7	1.9
17	Ethos	ETH-17.0	100	29.6	15	Y	3.8	3.3	2.4	1.7	1.2
17	Nagler 4	EN4-17.0	82	24.3	17	Y	3.8	3.3	2.4	1.7	1.2
<b>1 1/4" Eyepieces for Wide True Fields</b>											
40	Plössl	EPL-40.0	43	27.0	28	Y	8.9	7.7	5.7	4.0	2.9
32	Plössl	EPL-32.0	50	27.0	22	Y	7.1	6.2	4.6	3.2	2.3
24	Panoptic	EPO-24.0	68	27.0	15	Y*	5.3	4.6	3.4	2.4	1.7
13	Ethos	ETH-13.0	100	22.3	15	Y	2.9	2.5	1.9	1.3	0.9
16	Nagler 5	EN5-16.0	82	22.1	10	N	3.6	3.1	2.3	1.6	1.1
19	Panoptic	EPO-19.0	68	21.3	13	Y*	4.2	3.7	2.7	1.9	1.4
25	Plössl	EAP-25.0	50	21.2	17	N	5.6	4.8	3.6	2.5	1.8
17.3	Delos	EDL-17.3	72	21.2	20	Y	3.8	3.3	2.5	1.7	1.2
18.2	DeLite	EDE-18.2	62	19.1	20	Y	4.0	3.5	2.6	1.8	1.3
10	Ethos	ETH-10.0	100	17.7	15	Y	2.2	1.9	1.4	1.0	0.7
13	Nagler 6	EN6-13.0	82	17.6	12	Y*	2.9	2.5	1.9	1.3	0.9
14	Delos	EDL-14.0	72	17.3	20	Y	3.1	2.7	2.0	1.4	1.0
20	Plössl	EAP-20.0	50	17.1	14	N	4.4	3.8	2.9	2.0	1.4
11	Apollo	EAL-11.0	85	16.2	18	Y	2.4	2.1	1.6	1.1	0.8
15	DeLite	EDE-15.0	62	16.0	20	Y	3.3	2.9	2.1	1.5	1.1
<b>1 1/4" Eyepieces for Medium Powers</b>											
12	Delos	EDL-12.0	72	15.0	20	Y	2.7	2.3	1.7	1.2	0.9
13	DeLite	EDE-13.0	62	13.8	20	Y	2.9	2.5	1.9	1.3	0.9
10	Delos	EDL-10.0	72	12.7	20	Y	2.2	1.9	1.4	1.0	0.7
15	Plössl	EAP-15.0	50	12.6	10	N	3.3	2.9	2.1	1.5	1.1
9	Nagler 6	EN6-09.0	82	12.4	12	Y*	2.0	1.7	1.3	0.9	0.6
11	DeLite	EDE-11.0	62	11.7	20	Y	2.4	2.1	1.6	1.1	0.8
9	DeLite	EDE-09.0	62	9.6	20	Y	2.0	1.7	1.3	0.9	0.6
11	Plössl	EAP-11.0	50	9.1	8	N	2.4	2.1	1.6	1.1	0.8
<b>1 1/4" Eyepieces for Higher Powers</b>											
8	Ethos	ETH-08.0	100	13.9	15	Y	1.8	1.5	1.1	0.8	0.6
6	Ethos	ETH-06.0	100	10.4	15	Y	1.3	1.2	0.9	0.6	0.4
8	Delos	EDL-08.0	72	9.9	20	Y	1.8	1.5	1.1	0.8	0.6
7	Nagler 6	EN6-07.0	82	9.7	12	Y*	1.6	1.3	1.0	0.7	0.5
4.7	Ethos SX	ETH-04.7	110	8.9	15	Y	1.0	0.9	0.7	0.5	0.3
6	Delos	EDL-06.0	72	7.6	20	Y	1.3	1.2	0.9	0.6	0.4
7	DeLite	EDE-07.0	62	7.5	20	Y	1.6	1.3	1.0	0.7	0.5
3.7	Ethos SX	ETH-03.7	110	7.0	15	Y	0.8	0.7	0.5	0.4	0.3
5	Nagler 6	EN6-05.0	82	7.0	12	Y*	1.1	1.0	0.7	0.5	0.4
8	Plössl	EAP-08.0	50	6.5	6	N	1.8	1.5	1.1	0.8	0.6
4.5	Delos	EDL-04.5	72	5.6	20	Y	1.0	0.9	0.6	0.5	0.3
5	DeLite	EDE-05.0	62	5.3	20	Y	1.1	1.0	0.7	0.5	0.4
3.5	Nagler 6	EN6-03.5	82	4.8	12	Y*	0.8	0.7	0.5	0.4	0.3
3.5	Delos	EDL-03.5	72	4.4	20	Y	0.8	0.7	0.5	0.4	0.3
4	DeLite	EDE-04.0	62	4.3	20	Y	0.9	0.8	0.6	0.4	0.3
3	DeLite	EDE-03.0	62	3.2	20	Y	0.7	0.6	0.4	0.3	0.2
<b>1 1/4" Zoom Eyepieces for Medium and Higher Powers</b>											
6-3	Nagler Zoom	ENZ-0306	50	5.1-2.6	10	N	1.3-0.7	1.2-0.6	0.9-0.4	0.6-0.3	0.4-0.2

NOTE: True Field in degrees = (Field Stop dia./Telescope Focal Length) X 57.3°

\*Indicates additional Dioptx Adapter required

As of January 2012, all Tele Vue eyepieces have a limited lifetime warranty.



32 Elkay Dr., Chester, New York, 10918 (845) 469-4551 [televue.com](http://televue.com)